

# INSTALLATION INSTRUCTIONS

## ALUMINUM TRUCK CAP



**APPLICATION:**  
24+ Ranger Crew Cab 5' Bed

**PART NUMBER:** 16-11295S  
16-11295

CONTENT			
ITEM	QUANTITY	DESCRIPTION	TOOLS NEEDED
1	1	ROOF PANEL	13mm SOCKET
2	1	FRONT PANEL (SLIDING WINDOW OPTIONAL)	12mm SOCKET
3	1	LEFT SIDE PANEL	10mm SOCKET
4	1	RIGHT SIDE PANEL	RATCHET
5	1	REAR DOOR	TORQUE WRENCH
6	1	PARTS KIT #1	5MM ALLEN KEY
7	1	PARTS KIT #2	PHILLIPS SCREW-DRIVER
8	1	PARTS KIT #3	T-25 TORX BIT
9	1	FOAM SPACER	
10	1	INTERIOR LIGHT HARNESS	
11	1	LOCK/UNLOCK HARNESS	

**ANTI-SEIZE LUBRICANT MUST BE USED ON ALL STAINLESS STEEL FASTENERS TO PREVENT THREAD DAMAGE AND GALLING**

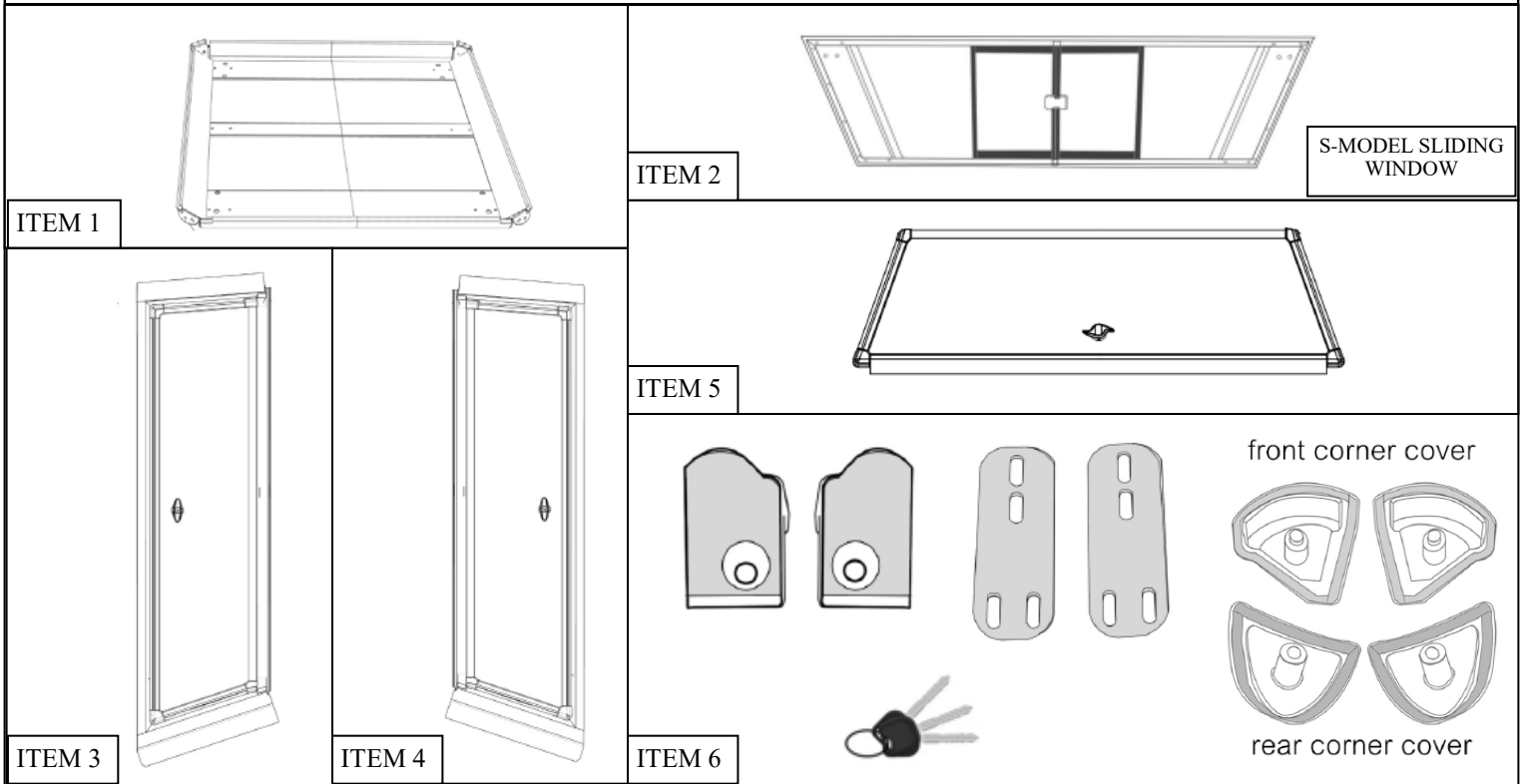

**WESTIN** Westin Automotive Products, Inc.  
320 W. Covina Blvd  
San Dimas, Ca. 91773

Thank you for choosing Westin products  
for additional installation assistance please call  
Customer Service (800) 793-7846  
www.westinautomotive.com

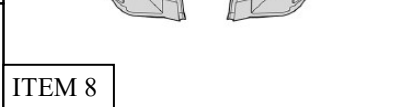
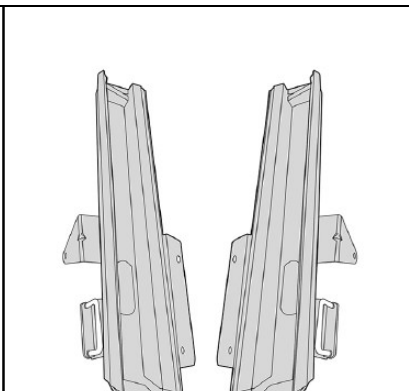
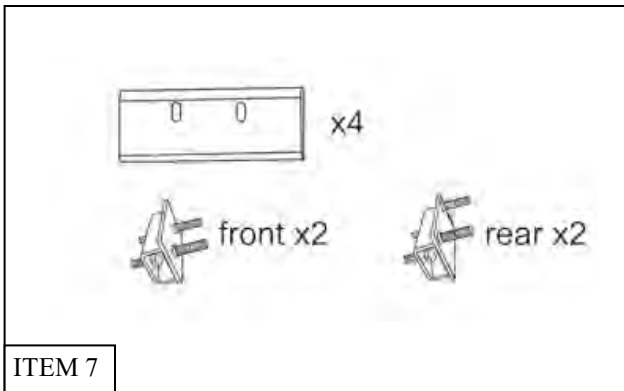

**PROCEDURE**

1. Remove contents from box, verify if all parts listed are present and free from damage. Carefully read and understand all instructions before attempting installation. **Failure to identify damage before installation could lead to a rejection of any claim.**
2. With the roof panel secured on a flat surface, slide the rear door into the roof panel. (Fig. 1)
3. Next, use a Phillips screwdriver to screw the three (3) #6 x 3/8 pan head tapping screws from **Parts Kit #1 (Item 6)** to secure the rear door panel onto the roof panel. Cross section view A-A shows how the railing system works to attach these components together. (Fig. 2)

FIGURE 1

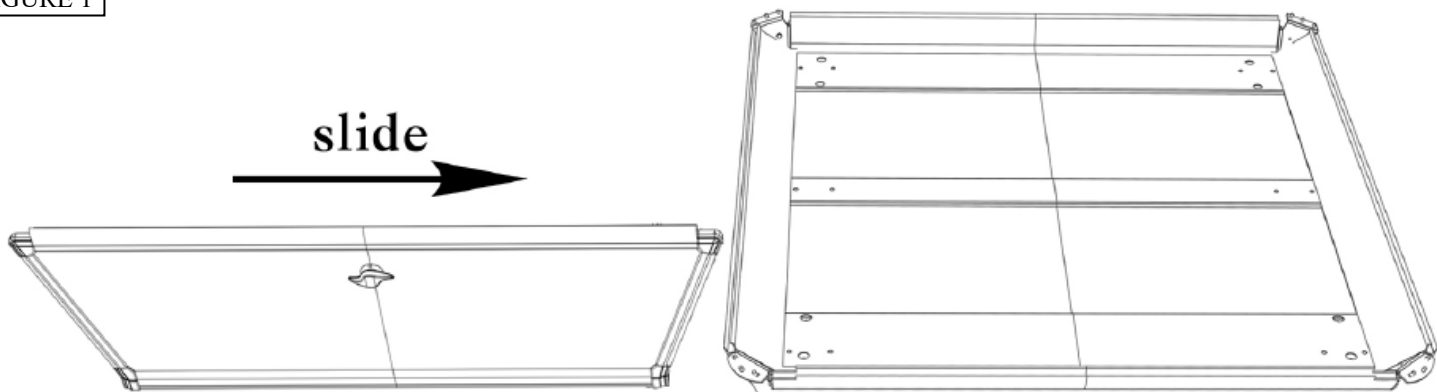
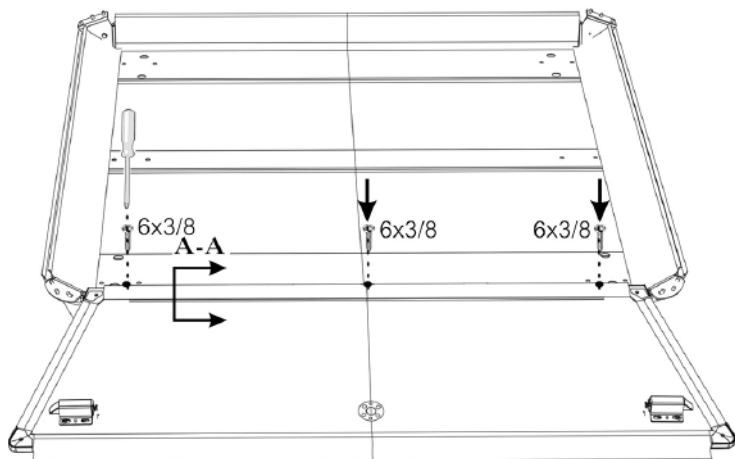
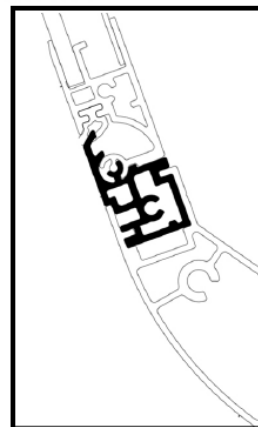

FIGURE 2



A-A



4. Screw in the rear door side covers using the two (2) #7 x 1/2 flat head tapping screws from **Parts Kit #1 (Item 6)**. The installation should look like the image below. **(Fig. 3)**

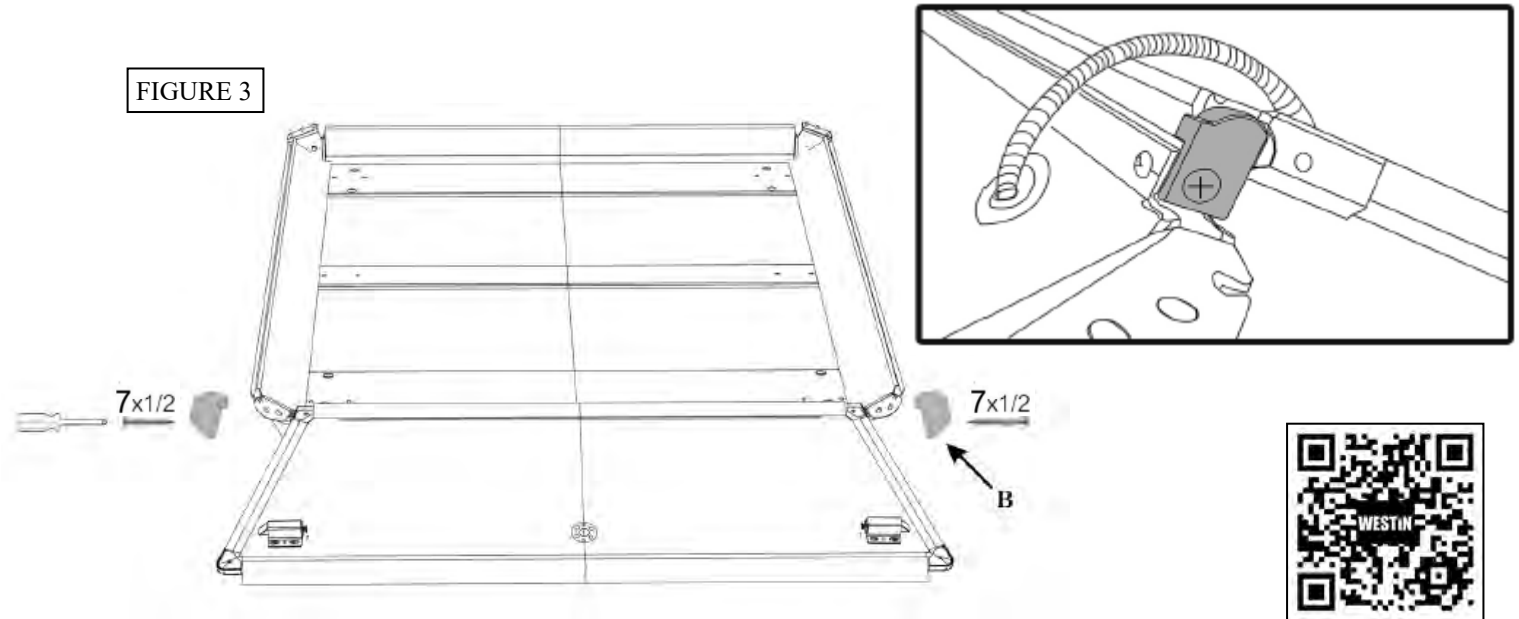

5. While lifting the rear door up, slide the left panel into the railing system. Section view A-A shows how the left panel slides into the roof panel. **(Fig. 4)**

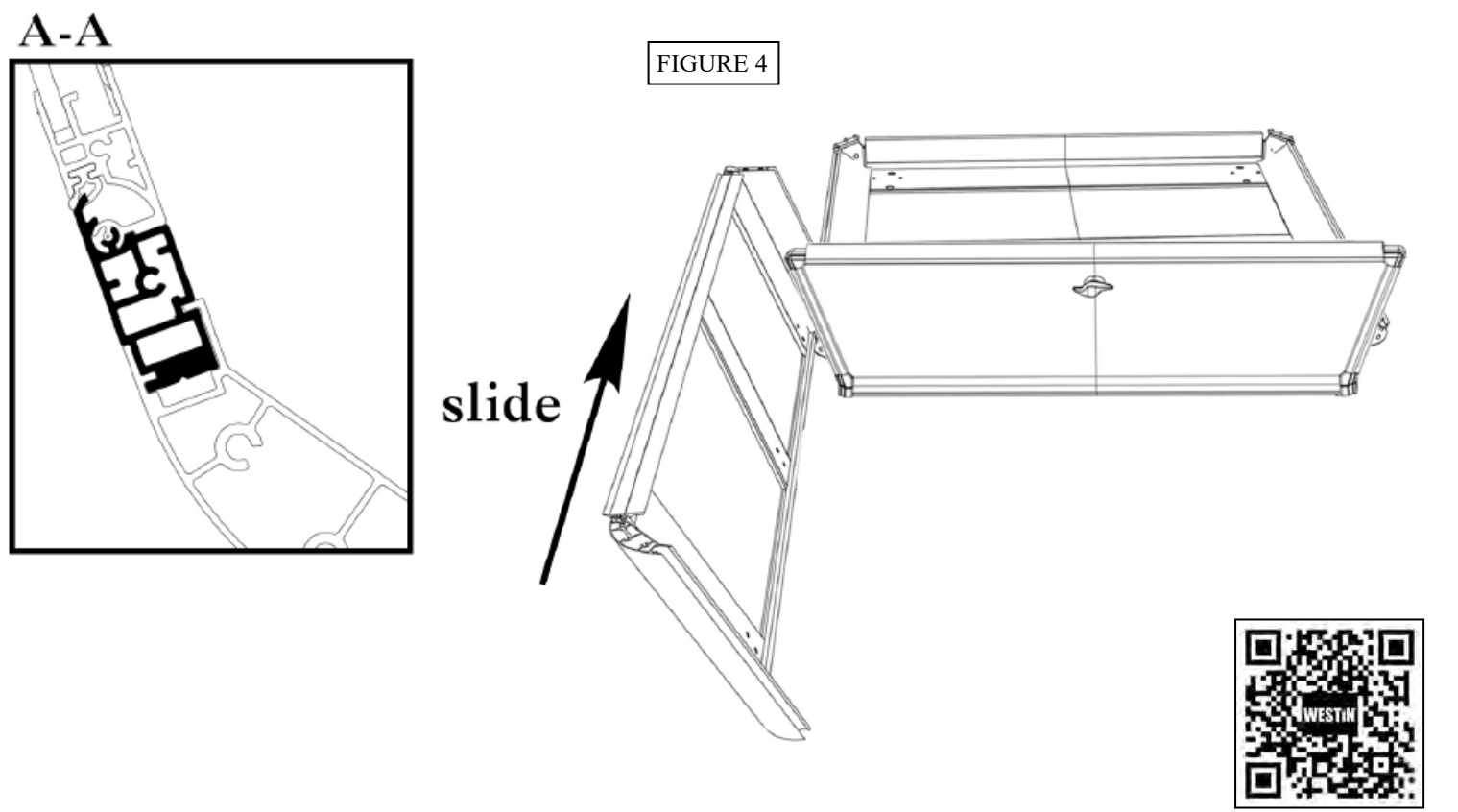

6. Repeat step 5 for the right panel. (Fig. 5)

FIGURE 5

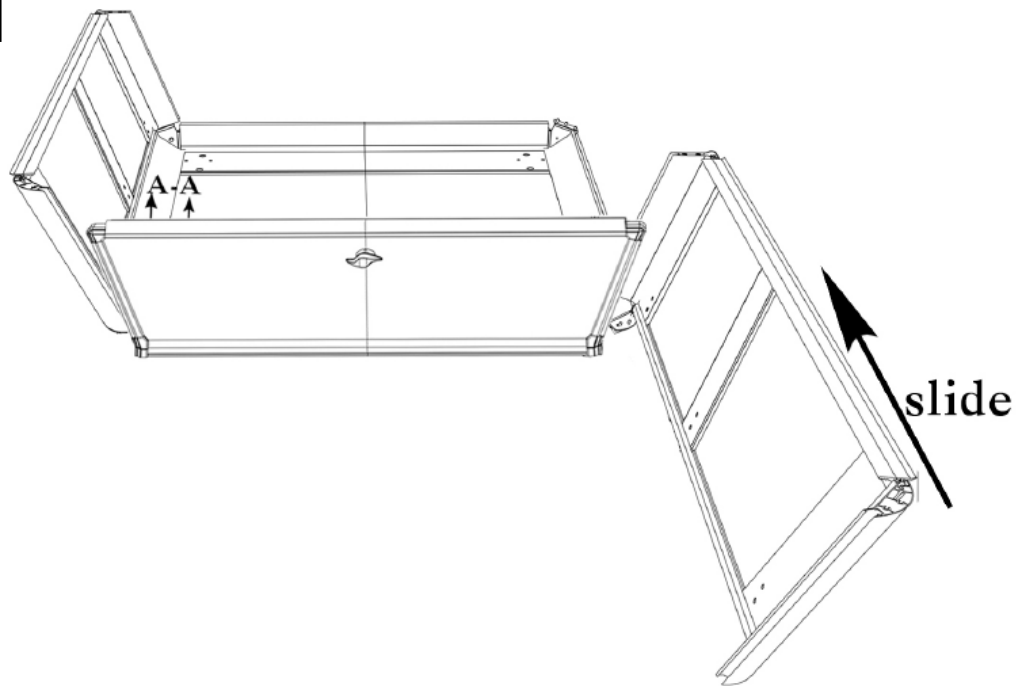

7. Next, push the front panel into the roof panel. (Fig. 6)

FIGURE 6

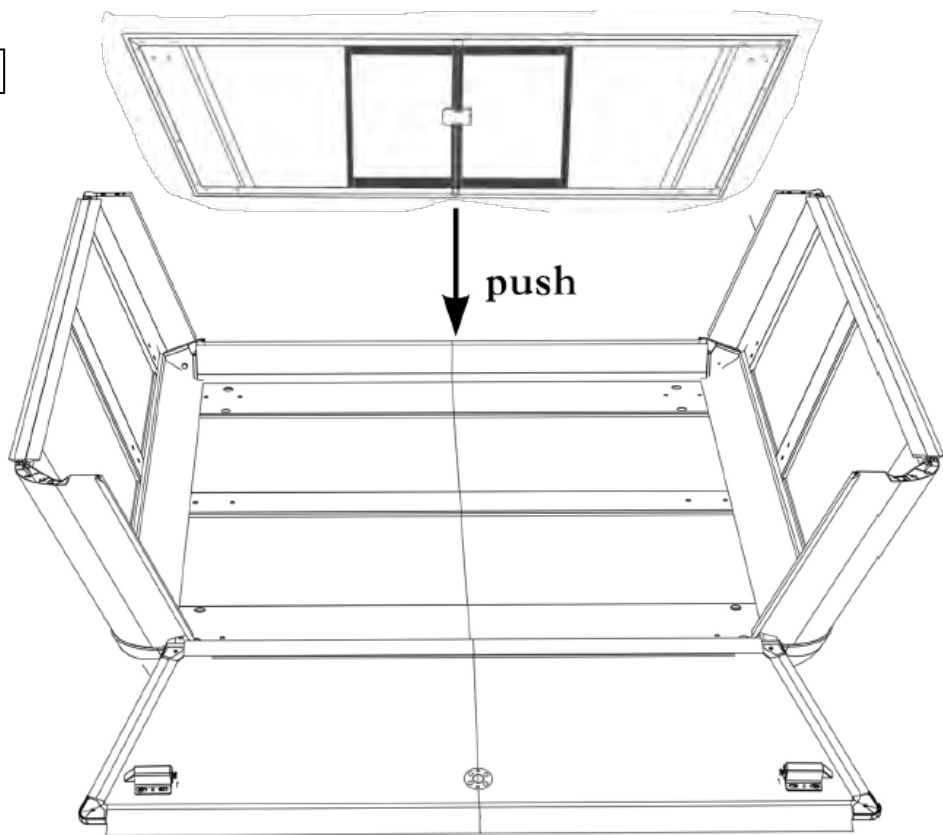

8. Push the left panel inwards towards the front panel. Using a front panel bracket, two (2) M8 x 12 socket pan head bolts, two (2) M8 split washers, two (2) M8 flat washers, two (2) M6 x 15 hex bolts, two (2) M6 split washers, and two (2) M6 flat washers provided in **Parts Kit #1 (Item 6)**, fasten the left panel to the front panel. Use a 5mm Allen Key and 10mm socket to initially tighten the bolts, then use a torque wrench to torque the M8 bolts to **10Nm (8ft-lbs)** and the M6 bolts to **5Nm (4 ft-lbs)**. Repeat this process to fasten the right panel to the front panel. (**Fig. 7**)

**CAUTION: MAKE SURE TO USE THE M8 X 12 SOCKET PAN HEAD BOLTS FOR THE MOUNTING HOLES ON THE FRONT GLASS, THEY REQUIRE A 5MM ALLEN KEY TO FASTEN. DO NOT USE THE M8 X 20 HEX BOLTS AS THIS MAY DAMAGE THE FRONT GLASS PANEL.**

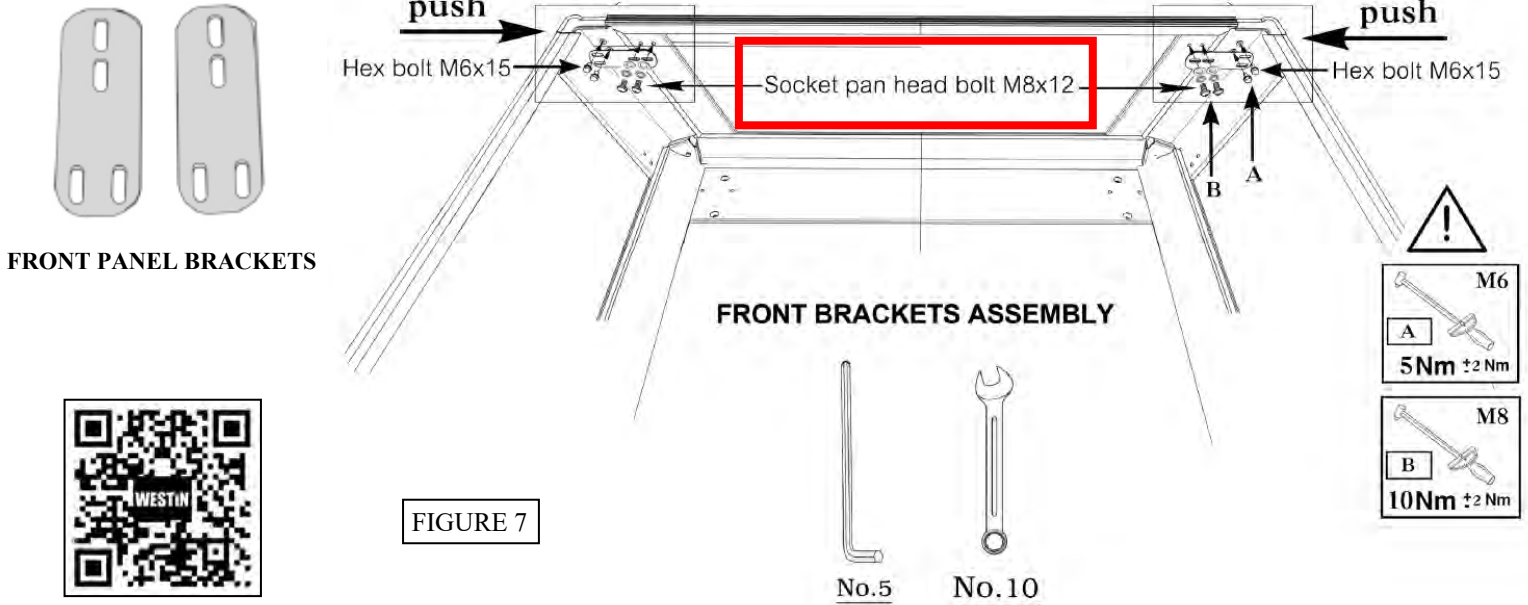

9. Connect the front wire found at the corner of the roof panel and front panel (**Fig. 8**). Then connect the rear wire (**Fig. 9**) and tuck the connectors into the roof panel. (**Fig. 10**)

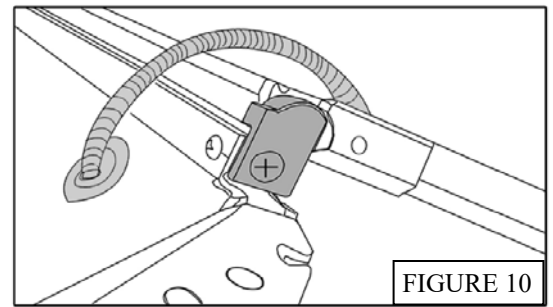
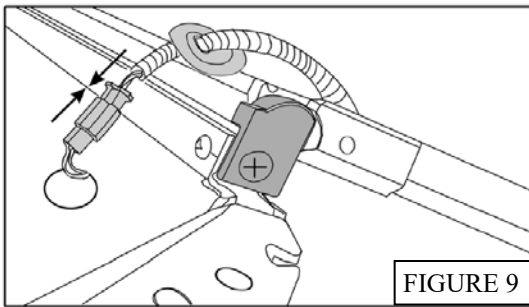
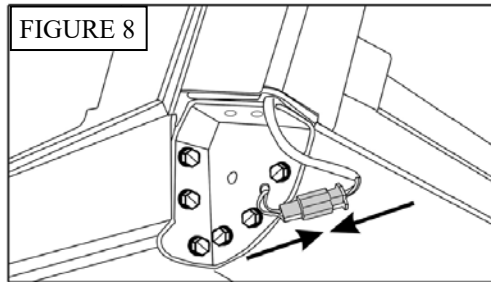

10. Next, use two (2) M8 x 20 Grade 8.8 hex bolts, two (2) M8 split washers, and two (2) M8 flat washers to fasten the front panel to the roof panel at one corner. Use a 13mm socket to initially tighten the bolts, then torque the bolts to **25Nm (19ft-lbs)**. Repeat this process for the other corner where the roof panel and front panel meet. (**Fig. 11**)

FIGURE 11

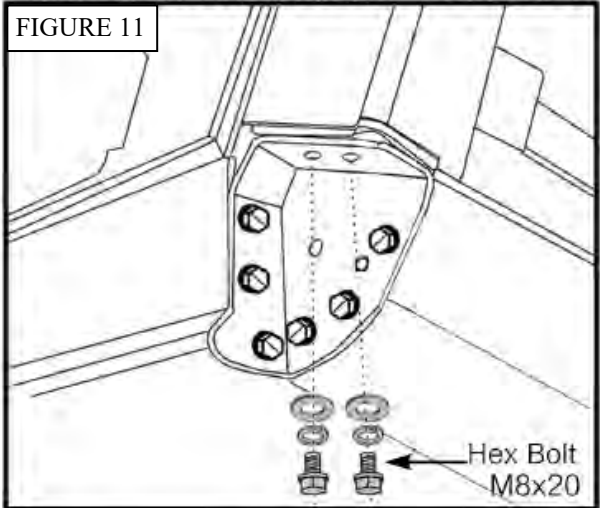

11. Repeat Step 10 for both corners where the roof panel and rear door meet. Use the same kind of hardware as in the previous step (**Fig. 12**). Connect the roof panel wire to the rear door connector as shown below. (**Fig. 13**)

FIGURE 12

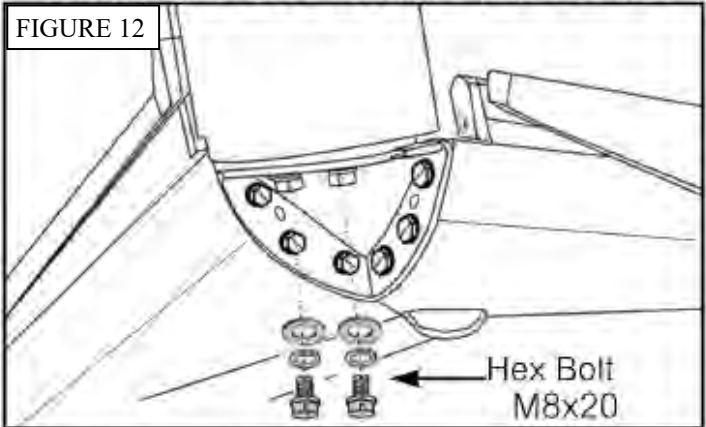
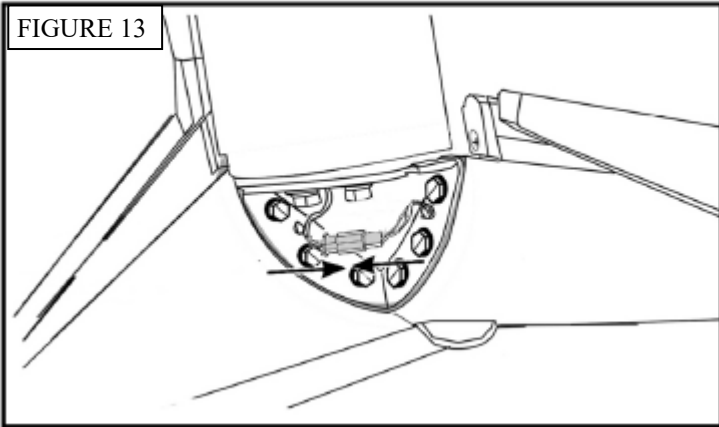
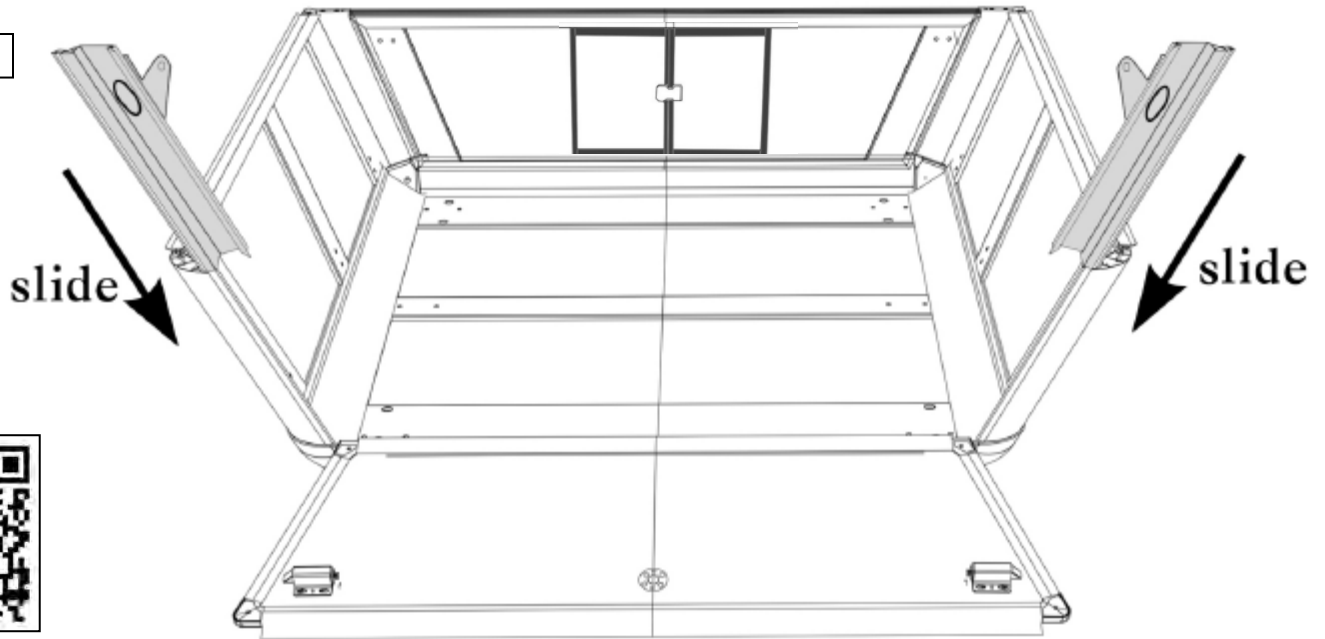

FIGURE 13



12. Slide the water channels downwards on the left and rear panels toward the rear door (Fig. 14). The water channels are found in **Parts Kit #3 (Item 8)**.

FIGURE 14



13. An inside corner of the rear door and side panel is shown below. Using the contents of **Parts Kit #3 (Item 8)** and a 12mm socket, fasten two (2) M8 x 20 hex bolts through the water channel bracket and into the side panel, torque to **10Nm (8ft-lbs)**. (Fig. 15) Next, use two (2) #6 x 3/8 pan head tapping screws and fasten the water channels to the side panels. (Fig. 16) Repeat this step for the other side of the topper.

FIGURE 15

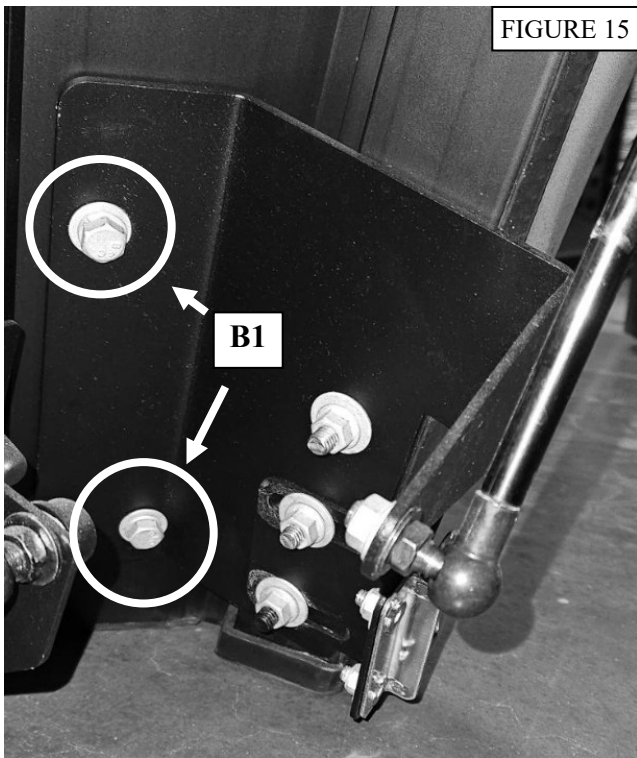
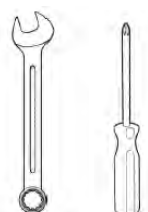

FIGURE 16



A1	
5 Nm ±2 Nm	
B1	
10 Nm ±2 Nm	



No. 12

14. Torque the nuts on the door latch to **5Nm (4ft-lbs)** using a 10mm socket. There are slots on the door latch bracket that allow for the latch to be adjusted so the rear door can close correctly. (**Fig 17**) Once the rear door is shut and the door latch is adjusted properly, torque the bolts in **Fig. 18** to **10Nm (8ft-lbs)**.

**SLOTS FOR ADJUSTABILITY**

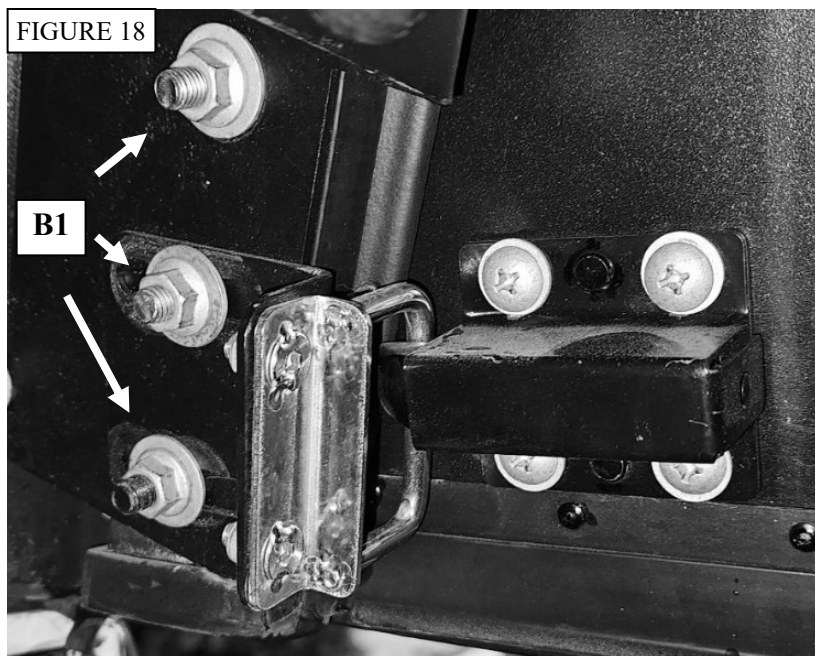
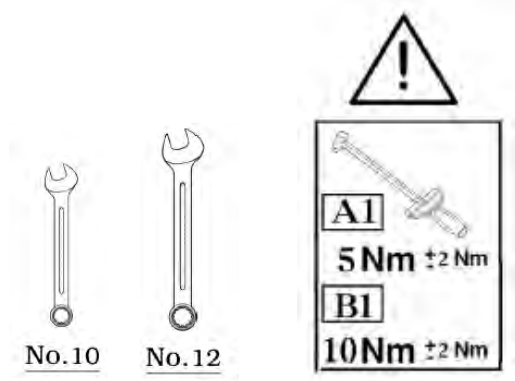
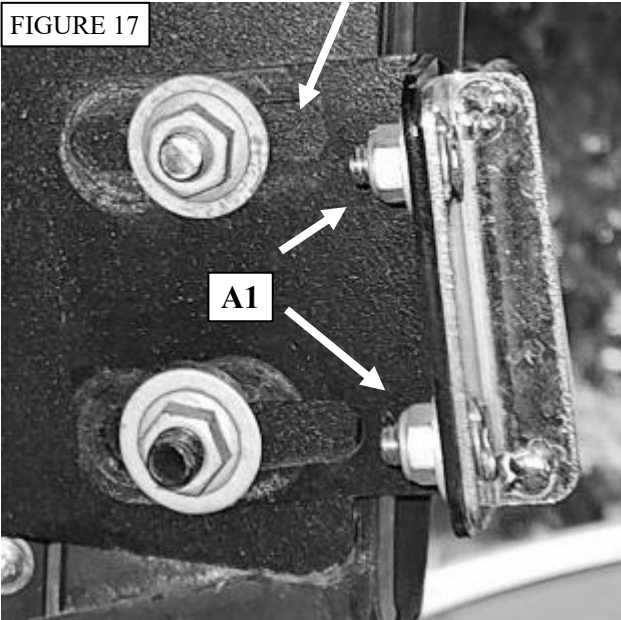

15. Next, clean the surface of the perimeter of the corner where the roof panel and left panel meet. Locate the silicone corner covers in **Parts Kit #1 (Item 6)** and remove the tape over the adhesive on the covers. While tucking the wires inwards into the roof panel, firmly press the cover over the corner (**Fig. 19**). Fasten the corner cover to the topper assembly using one (1) M6 x 10 pan head bolt and one (1) M6 flat washer also found in the same parts kit. The hardware fastens from the inside of the topper assembly. Repeat this step for installing the corner cover on the other side where the right panel meets the roof panel. (**Fig. 20**)

FIGURE 19

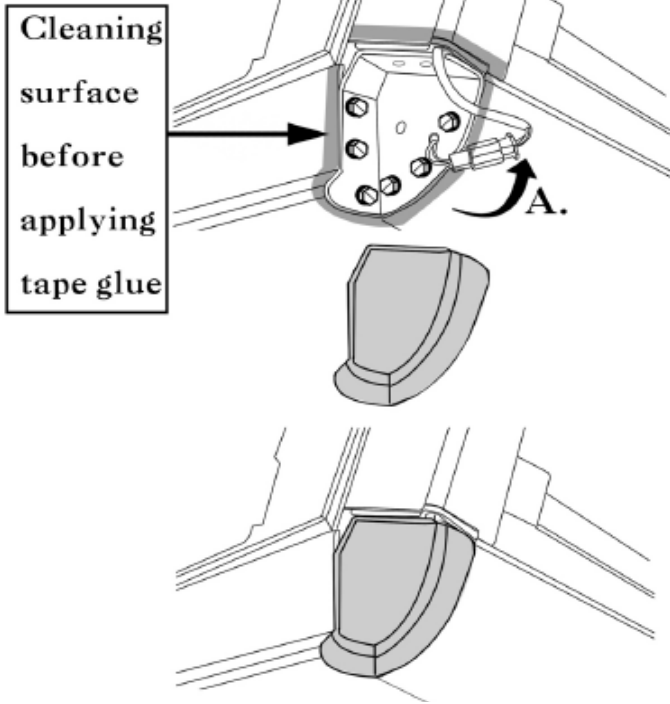
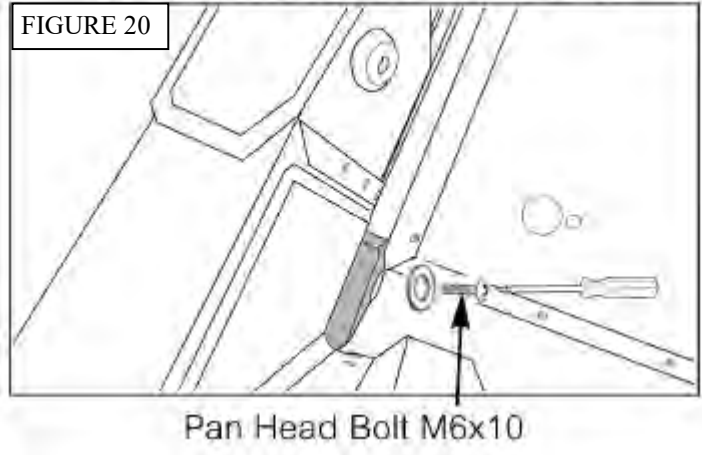
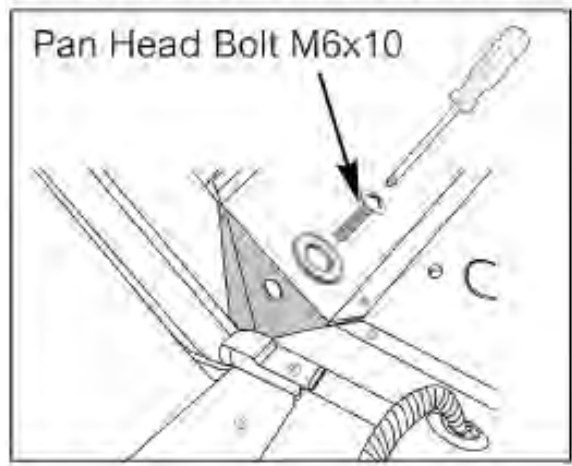
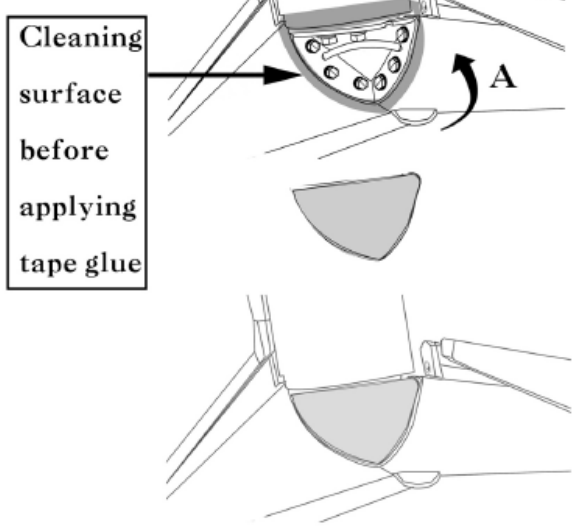

FIGURE 20



16. Repeat the process in Step 14 to install the corner covers on the rear corners of the topper assembly. (**Fig. 21**)

FIGURE 21



17. Locate the contents found in **Parts Kit #2 (Item 7)** and correctly place each labeled bottom clamp on both bed rails (**Fig. 23**). Use a 10mm socket to initially tighten the clamps, then torque to **5Nm (3.7ft-lbs)**. The tightened clamp should resemble (**Fig. 24**).

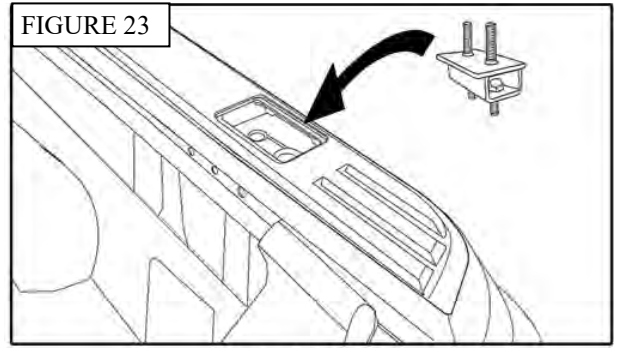
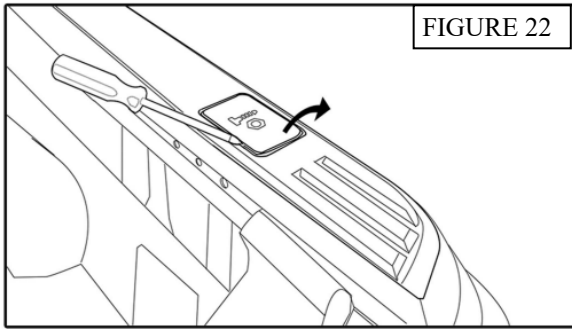

rear LH-RH

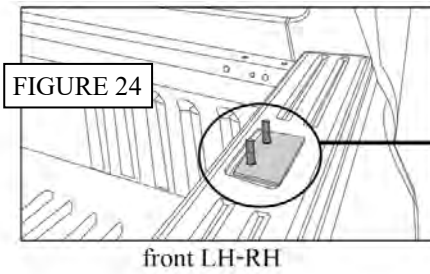

front LH-RH

Bottom view

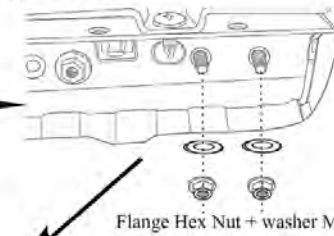

Flange Hex Nut + washer M10



No. 12

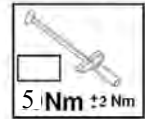

18. Remove adhesive on the included foam spacer (**Item 9**) and install it onto the front edge of the bed. Open the left, right, and rear panels before placing the topper onto the truck bed. A minimum of four people are recommended for this installation. Make sure to avoid dragging the topper across the truck bed rails. Handle with caution to avoid injury to hands and damage to the topper assembly and vehicle. (**Fig. 25**)

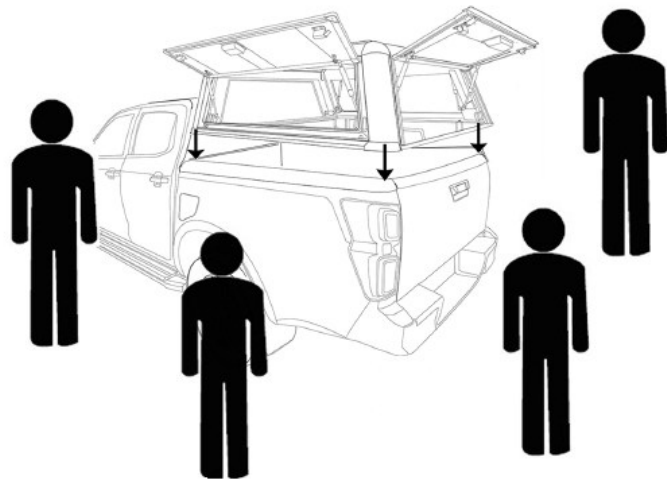
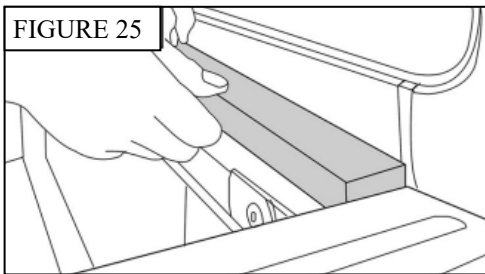

19. Locate the contents found in **Parts Kit #2 (Item 7)** and correctly place each labeled top clamp on both bed rails (**Fig. 26**). Use a 13mm socket to initially tighten the top clamps, then torque to **5Nm (3.7ft-lbs)**. The tightened top clamp should resemble (**Fig. 27**).

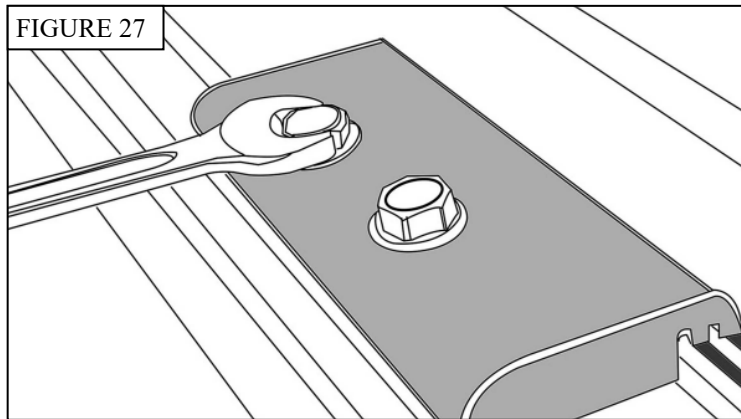
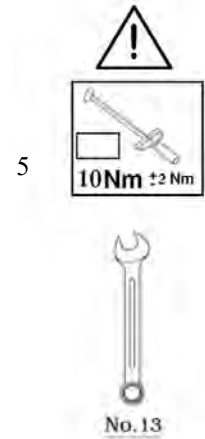
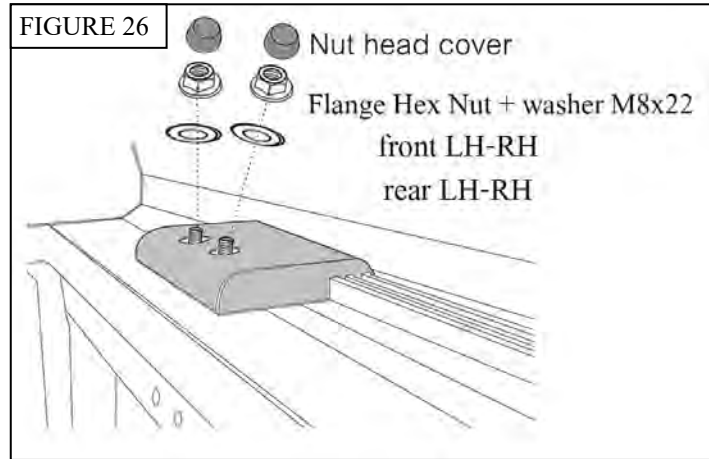

20. Once the bed topper is placed on the vehicle, adjustment may be required to allow for the topper to sit well onto the bed rails. If adjustment is needed, loosen the front bracket and push the sides doors inward towards each other and make sure the gap (circled in Fig. 28) is closed. Tighten the front bracket as mentioned in Step 8.



21. Use the nuts already installed on the end of the gas studs to secure the studs to the rear door using a 12mm socket. (Fig. 29)

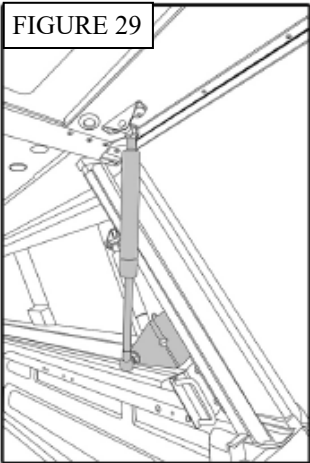

## Truck Cap Lock/Unlock Wiring Instructions

22. Use the provided Lock/Unlock Harness (**Item 11**) to connect to the plug underneath the vehicle's bed. (**Fig. 30**) Route the provided harness upwards into the area behind the passenger side tail light. Reference the procedure shown in the video tutorial (see qr code).
23. Remove the passenger side tail light using a T-25 Torx bit.
24. Next, route the white connector from behind the tail light and into the truck bed. Push the white connector through the rubber grommet on the wire coming from the rear right pillar of the truck cap (**Fig. 31**). Connect the provided harness to the white connector coming from the rear right pillar of the truck cap (**Fig. 32**).
25. Tuck the wires into the rear right pillar of the topper and install the rubber grommet (**Fig. 33**).
26. Connect the two wires located at the top rear passenger side corner of the truck cap. Tuck the rubber grommet into the cap (**Fig. 34**).

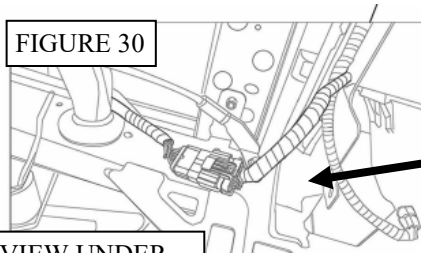

FIGURE 30

VIEW UNDER  
TRUCK BED

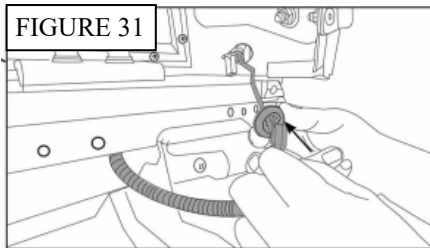
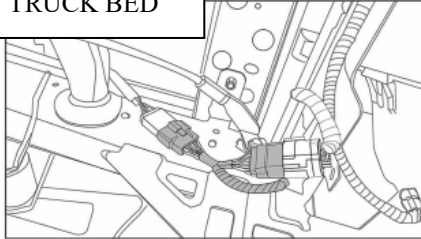

FIGURE 31

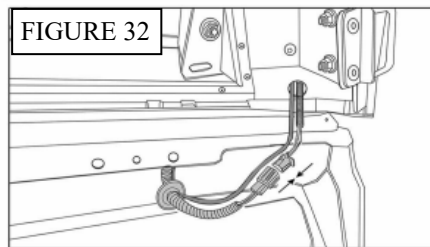

FIGURE 32

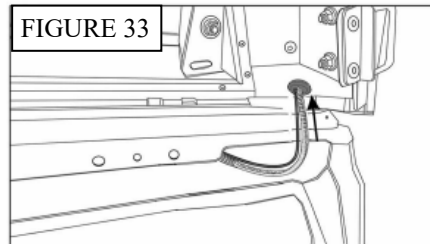

FIGURE 33

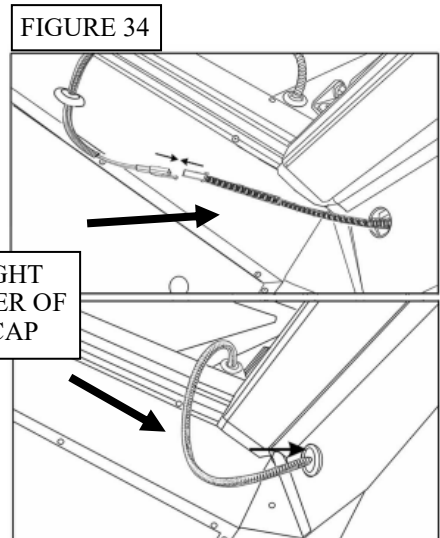

FIGURE 34

REAR RIGHT  
TOP CORNER OF  
TRUCK CAP

## Truck Cap Brake Light Wiring Instructions

27. With the passenger side tail light still removed, route the wires with the blue splice connectors coming from the rear right pillar of the truck cap through the vehicle's bed, and into the passenger side tail light area.
28. Locate the brake light socket on the back of the tail light.
29. Use the blue splice connectors to splice the truck cap's red wire to the tail light's blue/brown wire. Then splice the truck cap's yellow wire to the tail light's black/yellow wire (**Fig. 35**).
30. Test that the truck cap's brake light functions correctly with the vehicle's brake lights.
31. Reinstall the passenger side tail light.

**Note:** If truck cap tail light does not function with vehicle's tail lights, switch wiring order.

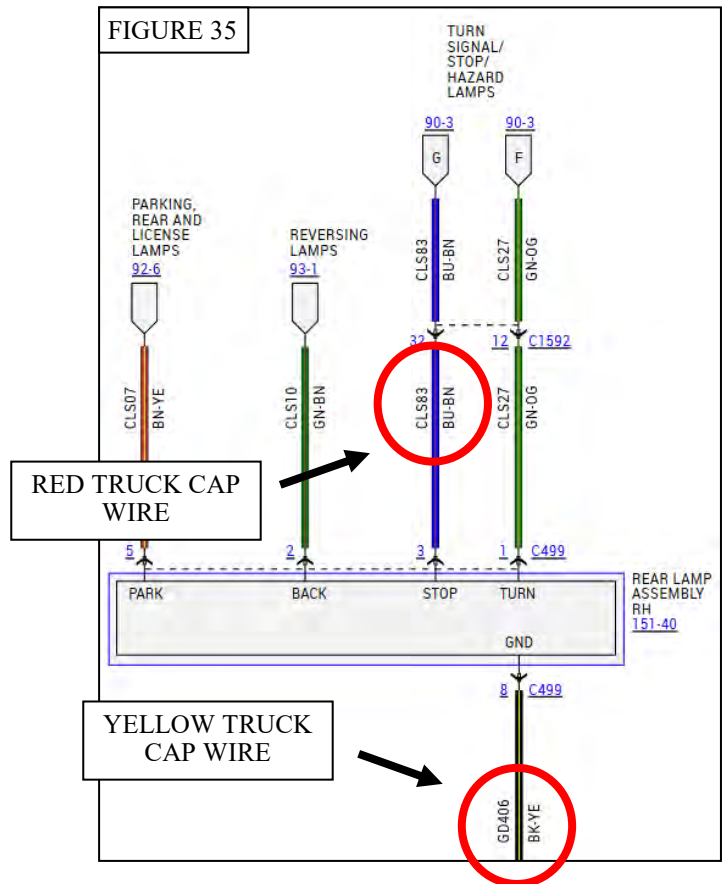
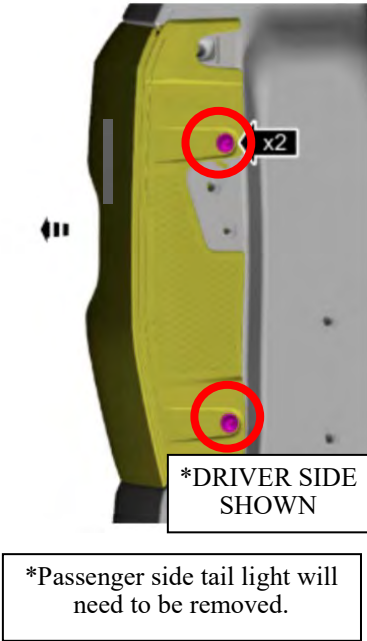

## LED INTERIOR LIGHT

32. Plug the provided Interior Light Harness (**Item 10**) at the connector coming from the rear driver side of the topper (**Fig 36**). Tuck the harness into the topper using the rubber grommet (**Fig 37**). The other end of the harness will need to go to the vehicle's battery. Route the harness underneath the vehicle, make sure to avoid any moving parts.

A key set is included in the truck cap packaging.

The installation of your Westin Automotive Aluminum Truck Cap is complete!

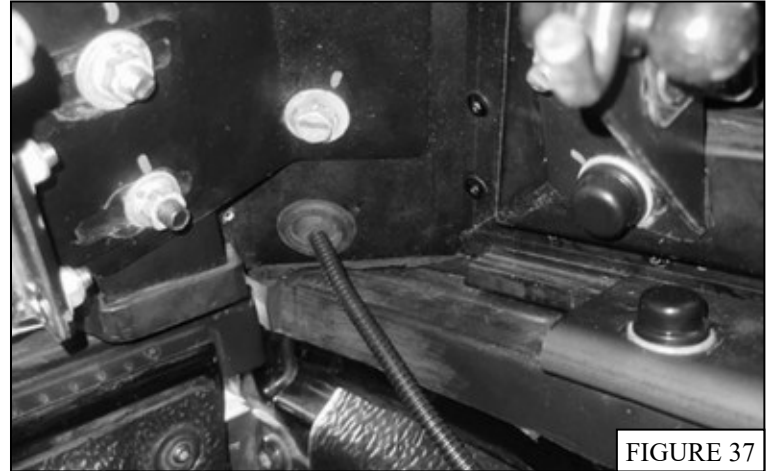
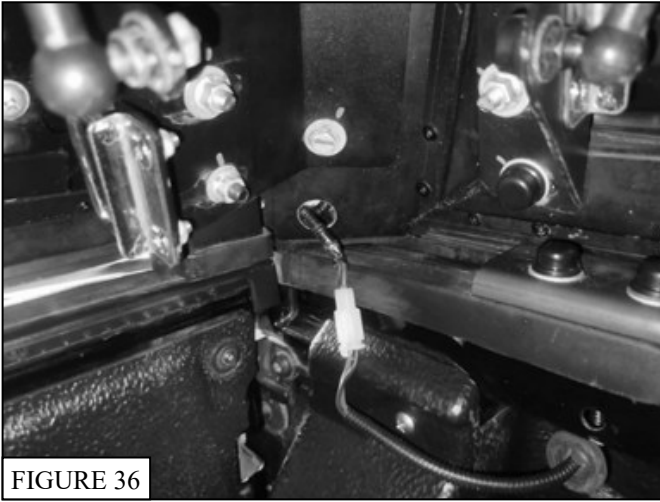



## WARNING



Failure to follow these instructions could lead to death, personal injury, and / or property damage.

Failure to follow these instructions could lead to death, personal injury, and / or property damage.

### FASTENERS:

All Westin supplied fasteners must be utilized and installed in accordance with the installation instructions and apply torque to the specifications as defined. **DOUBLE CHECK ALL FASTENERS BEFORE INITIAL USE, AND PERIODICALLY IN THE FUTURE TO ENSURE PROPER FUNCTION AND SAFETY.**

### DRILLING:

Most Westin products do not require drilling for installation. If drilling is defined as required, use caution when drilling a vehicle. **FAILURE TO REVIEW AN AREA TO BE DRILLED MAY RESULT IN PERSONAL INJURY AND/OR INJURY TO OTHERS AS WELL AS VEHICLE DAMAGE.**

### EYE PROTECTION:

**ALWAYS WEAR SAFETY GLASSES OR GOGGLES DURING THE INSTALLATION PROCESS TO AVOID PERSONAL INJURY.**

### MAXIMUM TOWING/CARRYING CAPACITY: (if applicable)

The Westin Receiver Hitches will have a visible tow rating label affixed directly on the product. User should never exceed the vehicle manufacturers maximum tow and weight rating regardless of the capacity of the hitch. **FAILURE TO FOLLOW THESE GUIDELINES WILL VOID THE WESTIN WARRANTY AND MAY RESULT IN PERSONAL INJURY AND/OR INJURY TO OTHERS AS WELL AS VEHICLE DAMAGE.**

### FOR CALIFORNIA RESIDENTS ONLY-PROP 65 WARNING:

Some products may contain chemicals such as DEHP, which can cause cancer, birth defects or other reproductive harm. For more info go to [www.p65warnings.ca.gov](http://www.p65warnings.ca.gov)



Westin Automotive Products, Inc.  
320 W. Covina Blvd  
San Dimas, Ca. 91773